

Product Information

Electromechanical Testing Machines **LabTest 6.030 - 6.050**

Machine use

Electromechanical universal testing machines of the series 6.xxx.1 with new design are intended for the mechanical tests in tensile, compression and bending during loading of specimens and whole products. Double columns bench top or floor top designs with capacity from 3 kN to 5 kN are produced with different heights of testing areas from 510 to 1910 mm and widths 412 and 512 mm. The machine frame can be extended to several testing areas (3).

Machine description and the main advantages

- The testing machine is equipped with a ball screw with preload and a linear guide, which allows partial out off-axis loading of specimens.
- Robustness of the frame ensures high rigidity, durability and resistance against vibration and mechanical damage.
- Machine and working area ergonomic allows easy manipulation with specimens and accessories.
- AC servo drive and belt drive with low noise level ensures low maintenance claims of the machine during tensile and compression testing.
- Ability to manage the machine speed in the range of 0.0005 to 3000 mm/min.
- A modular configuration of the machine with the ability to add any accessories from LABORTECH company, including extensometers, temperature chambers, probes, tools, protection covers etc.
- Due to high data acquisition rate **1 kHz** and high resolution of AD converters **24 bit**, the measuring electronics allows very accurate testing in a large measuring range of the loading cell without any retrofitting of the machine with another sensor.
- High operator comfort and customization tools for specific customer requirements, such as special protective covers, different speeds, different types of special grips, adjustments of X-head travel for custom tools etc.
- Ability to control the machine with a remote control RMC 6 with one button via PC or tablet.

Supplements and Accessories

- Wide range of grips, compression and bending tools
- Extensometers (mechanical, contactless)
- Special temperature chambers high temperature furnaces
- Pneumatic aggregate for grips control
- Possibility of delivery with additional testing areas

The base machine includes:

- Machine frame including electronics EDC 220
- Bench top design or table version
- "S" series load cell for tension/pressure at full loading
- Remote control RMC 6 with LCD display
- Software integrated in the remote control



Software Test & Motion®

- Simple, intuitive and efficient
- Definable all kinds of protocols printing
- Individual files programming
- A set of programs for your own individual testing
- Available almost all standard methods of evaluation
- Special specific applications, programmable modules
- Digital imaging of all channels
- Extensive statistics of results
- Saving of results data in ASCII format, SQL and Excel file
- Transferring data from other devices like touch thickness gauge, scales, etc.
- Compatibility with each EDC box system by Labortech company
- Possibility to add more additional channels
- Quick and efficient testing
- 9 languages (En, Cz, Ge, Fr, Pol, It, Sp, Ru, Du)
- Protocol printing in various languages
- Installation on any computer without a licence

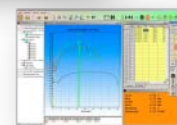

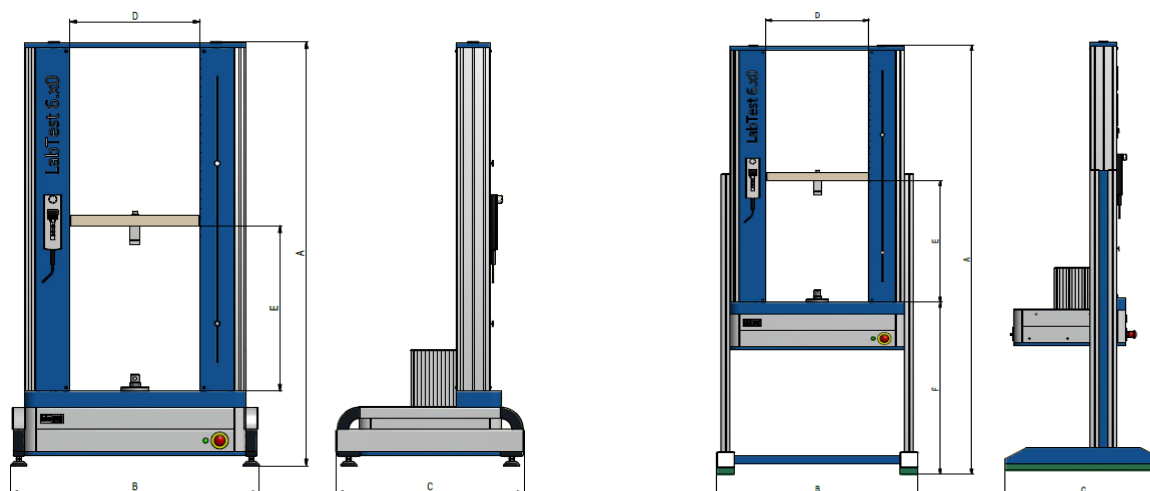

Technical data	Units	Units															
		6.030.1.00	6.030.1.10	6.030.1.20	6.030.1.30	6.030.1.11	6.030.1.21	6.030.1.31	6.050.1.00	6.050.1.10	6.050.1.20	6.050.1.30	6.050.1.11	6.050.1.21	6.050.1.31		
Load capacity	kN	3								5							
Number of columns										2							
Number of ball lead screws										2							
Number of linear guides										2+2							
Minimum testing speed	mm/min	0,0005								0,0005							
Maximum testing speed	mm/min	1200								600							
Travel resolution	μm	0,066								0,026							
Repeatability of X-head travel	μm	±2								±2							
Weight ¹	kg	88	98	108	115	113	123	130	88	98	108	115	113	123	130		
Dimensions²																	
Height of the Machine (A)	mm	900	1500	2000	2300	1500	2000	2300	900	1500	2000	2300	1500	2000	2300		
Width of the Machine (B)	mm	816	816	816	816	916	916	916	816	816	816	816	916	916	916		
Depth of the Machine (C)	mm	543	543	543	543	543	543	543	543	543	543	543	543	543	543		
Width of test space (D)	mm	412				512				412				512			
Height of test space (E)	mm	510	1110	1610	1910	1110	1610	1910	510	1110	1610	1910	1110	1610	1910		
Environmental conditions																	
Operating temperature	°C	10 to 35															
Storage temperature	°C	-35 to 55															
Humidity range	%	< 90															
Noise level ³	dB	< 58															
Electrical connection																	
Supply voltage	V	230 ... 240 / 50-60Hz								230 ... 240 / 50-60Hz							
Fuse	A	16								16							
Power Rating	kVA	0,370								0,370							

¹Without accessories

²Floor top version parameters: Changing parameters: extension dimension A in the range of +277 or +627 mm B +4 mm, C +357 mm, F +500mm or +850 mm. Stand weight 41 kg

³Measured at 1 m distance from testing machine without loading

Technical changes are reserved by manufacturer

Manufacturer:

LABORTECH s.r.o., Rolnická 130a, 747 05 Opava, Czech republic. Tel.: +420 553 731 956, +420 553 775 327
 Mob.: +420 602 527 646, +420 731 656 723, info@labortech.cz, www.labortech.cz, Czech republic

